

# TOOL STORAGE

CHEST	185
ROLLER CABINET AND WAGON	189
TOOL BOXES	196
STORAGE ACCESSORIES	201

# TOOL STORAGE

---

## CHEST

Watch video!  
How to use the chest



Click here  
how to use it.

**CHEST (3 STAGES, 3 DRAWERS)**



EKR-1003R



EKR-1003BK



EKR-1003



EKR-1003WH

No.	Weight(kg)	☐	
EKR-1003R(Red)	35	1	
EKR-1003BK(Black)	35	1	
EKR-1003(Silver)	35	1	
EKR-1003WH(White)	35	1	

Body size	W715×D390×H410 Handle (left/right) protrusion 85 φ29		
Top part	w695×d340×h65	Load capacity	20kg
Drawer size	w600×d325×h45×2	Load capacity	15kg
	w600×d325×h105×1	Load capacity	20kg
Top mat×1 Drawer mats×4 Dividers×2 Keys×2			

\* Repair parts are set.  
For details, please contact the distributor.

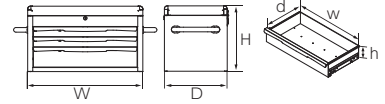

**CHEST (4 STAGES, 4 DRAWERS)**



Try out the tool case on your phone!



EKR-1004R



EKR-1004BK



EKR-1004



EKR-1004WH

No.	Weight(kg)	☐	
EKR-1004R(Red)	39	1	
EKR-1004BK(Black)	39	1	
EKR-1004(Silver)	39	1	
EKR-1004WH(White)	39	1	

Body size	W715×D390×H410 Handle (left/right) protrusion 85 φ29		
Top part	w695×d340×h65	Load capacity	20kg
Drawer size	w600×d325×h45×4	Load capacity	15kg
Top mat×1 Drawer mats×4 Dividers×2 Keys×2			

\* Repair parts are set.  
For details, please contact the distributor.

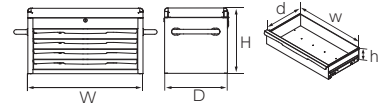

**FLAT CHEST (3 STAGES, 3 DRAWERS)**



EKR-2003R



EKR-2003BK



EKR-2003



EKR-2003WH

No.	Weight(kg)	☐	
EKR-2003R(Red)	33	1	
EKR-2003BK(Black)	33	1	
EKR-2003(Silver)	33	1	
EKR-2003WH(White)	33	1	

Body size	W715×D390×H330 Handle (left/right) protrusion 85 φ29		
	Top Area	Load capacity	20kg
Drawer size	w600×d325×h45×2	Load capacity	15kg
	w600×d325×h105×1	Load capacity	20kg
Top mat×1 Drawer mats×3 Dividers×2 Keys×2			

\* The EKR-1003 and EKR-1004 cannot be placed on top.  
\* Repair parts are set.  
For details, please contact the distributor.

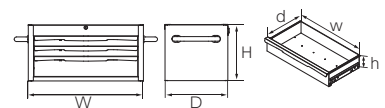

**Top cover**



The top cover and the grounding area of the main unit are joined not by a section of steel plate but by a surface joint method.

**Corner Bumper**



Corner bumpers reduce the risk of accidental injury. They also contribute to the protection of the chest itself.

**Large front mall**

All drawers are equipped with an inner latch mechanism to prevent accidental ejection. Separate mall and latches are used to increase durability.



**Rail guard**

Drawer rails are mounted with guides, and the use of 1.2 mm thick steel plates ensures the rigidity of the drawers, ensuring long-term comfort.



• Do not pull out more than two drawers at the same time. Possible to be fall down.  
Do not disassemble or modify the product.

## CHEST (3 STAGES, 3 DRAWERS)



Try out the tool case on your phone!



No.	EKR-103A		
Weight(kg)	13	1	
Body size	W510×D275×H325		
Top part	w445×d225×h75	Load capacity8.5kg	
Drawer (1st to 2nd drawer) (3rd drawer)	w420×d215×h45	Load capacity5kg	
	w420×d215×h75	Load capacity8.5kg	
Top mat×1 Drawer mats×3 Dividers×3			

- All drawers can be locked when all drawers are closed and the lids are closed.
- Can be locked with a padlock (sold separately).

\* Repair parts are available. Please contact our distributors for details.

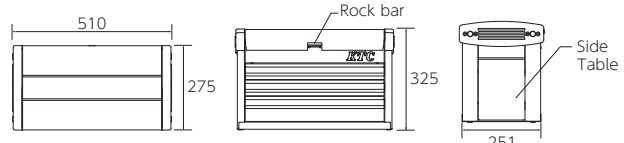

\* The "side table" is designed to be removed for optional installation.

### This shape because we focused on storage.



The top section can hold a 3/8"sq. deep socket, etc.



The third drawer can be made deeper to accommodate chemicals and other items that could not fit in the drawer before.



The drawer depth direction is also spacious, allowing for lean storage.



Foldable side table for small items. (Load capacity 2kg)



The drawer lock mechanism is released at about half the opening angle of conventional products\*. No need to open the top cover wide. \* Comparison with our SKX0213

### This shape is for storage plus



The top cover is designed to resemble an engine head cover. The built-in handle is close to shoulder-width when the chest is held, making it easy to move. The back of the handle has also been carefully designed to prevent hand pain.



The aluminum feet protecting the bottom of the chest not only protect the case itself, but also prevent unnecessary scratches on the installation site.

### SIDE TABLE

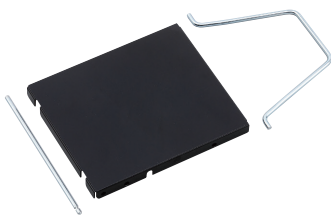

Condition of use

No.	W	D	H	Weight(g)	1
EKR-511	150	178	16	350	1

• This is a side table for the chest (EKR-103A).

• Foldable for small items.

\* Cannot be used in combination with EKR-103 dedicated side pockets (EKR-502S, EKR-502L).



• Do not put in more than the load capacity.

Load capacity : 2kg

### SIDE POCKET S/L FOR EKR-103

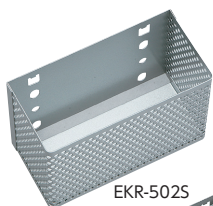

EKR-502S

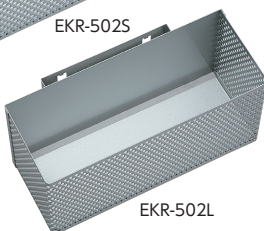

EKR-502L



Condition of use



Condition of use

No.	W	D	H	Weight(g)	1
EKR-502S	148	72	100	480	1
EKR-502L	250	100	121	900	1

• Side pocket for chest of drawers (EKR-103 series).

• You can put removed parts and small personal items.

• The cans can hold spray cans, rags, etc.

• Made of perforated metal.

\* Cannot be used with side table (EKR-511).



• Do not put in more than the load capacity.

Load capacity : 2kg

- Function mark is indicated under the product name. For the details, please refer to P.004-005.
- Products marked with should be ordered after checking stock.
- Do not pull out more than two drawers at the same time. Possible to be fall down.



Spare parts Repairable

**CHEST (4 STAGES, 6 DRAWERS)**

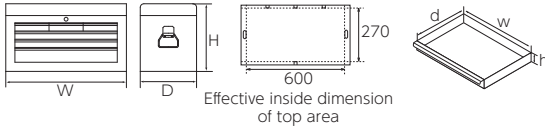

No.	Weight(kg)	☞	
SKX3306	23	1	
Body size	W660×D310×H370		
Top part	w650×d300×h65	Load capacity15kg	
Drawer size	w170×d270×h40×3	Load capacity10kg	
	w570×d270×h40×2	Load capacity15kg	
	w570×d270×h60×1	Load capacity15kg	
Top mat×1 Drawer mats : large×3, small×3 Dividers×3 Keys×2			

- Two stays with a stopper function are used to prevent accidental closing of the lid.
- Ball bearing slide rails are used for smooth opening and closing of drawers.
- All drawers can be locked when all drawers are closed and the lids are closed.
- \* Repair parts are available. Please contact our distributors for details.

**CHEST (3 STAGES, 3 DRAWERS)**



Try out the tool case on your phone!



SKX0213



SKX0213BK



SKX0213S

\* The photo is for illustrative purposes only. Do not open more than one drawer at a time.



Drawers have bearing rails for smooth opening and closing.



KTC logo embossed on the top.

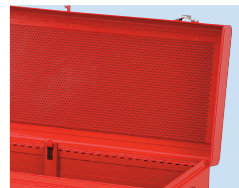

Rigid top panel with perforated panels.

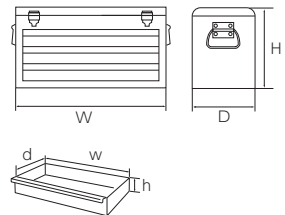

No.	Weight(kg)	☞	
SKX0213(Red)	11	1	
SKX0213BK(Black)	11	1	
SKX0213S(Silver)	11	1	
Body size	W520×D215×H300		
Top part	w500×d200×h60	Load capacity8.5kg	
Drawer size	w455×d190×h45×3	Load capacity5kg	
Top mat×1 Drawer mats×3 Dividers×3			

- The compact size of the chest allows for a large amount of storage space, and the side handles make it easy to carry.
- Ball bearing slide rails are used for smooth opening and closing of drawers.
- All drawers can be locked when all drawers are closed and the lids are closed.
- The product can be locked with padlocks, etc. (This product does not come with a key.)
- \* Repair parts are available. Please contact our distributors for details.

**CHEST (2 STAGES, 2 DRAWERS)**



Try out the tool case on your phone!



SKX0102



SKX0102BK



SKX0102S



This case is just size to be placed in a study or on a work desk.

No.	Weight(kg)	☞	
SKX0102(Red)	7.5	1	
SKX0102BK(Black)	7.5	1	
SKX0102S(Silver)	7.5	1	
Body size	W435×D240×H230		
Top part	w420×d225×h55	Load capacity8.5kg	
Drawer size	w380×d215×h45	Load capacity5kg	
Top mat×1 Drawer mats×2			

- The narrow chest of drawers is designed to be used on a desk.
- Ball bearing slide rails are used for smooth opening and closing of drawers.
- All drawers can be locked when all drawers are closed and the lids are closed.
- The product can be locked with padlocks, etc. (This product does not come with a key.)
- \* Repair parts are available. Please contact our distributors for details.

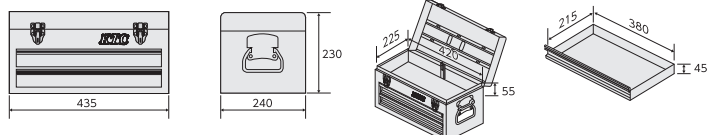

• Do not pull out more than two drawers at the same time. Possible to be fall down. Do not disassemble or modify the product.

**TOOL STORAGE**

---

**ROLLER CABINET  
AND WAGON**

ROLLER CABINET (5 STAGES, 5 DRAWERS)



EKW-1005R



EKW-1005BK



EKW-1005



EKW-1005WH

No.	Weight(kg)	⊠	
EKW-1005R(Red)	74	1	
EKW-1005BK(Black)	74	1	
EKW-1005(Silver)	74	1	
EKW-1005WH(White)	74	1	

Body size	W740×D470×H910(Including caster H180) Handle protrusion 85 φ29 Top section Load capacity140kg Maximum load capacity 350kg (including product weight)
Top Size	w720×d460
Drawer size	w600×d405×h 45×2 Load capacity15kg w600×d405×h105×2 Load capacity20kg w600×d405×h230×1 Load capacity30kg
Top mat×1 Drawer mats×7 Dividers×4 Keys×2	

· When all drawers are closed and locked, all drawers can be locked at the same time. All drawers locking system is adopted.

\* Repair parts are set.

For details, please contact the distributor.

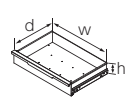
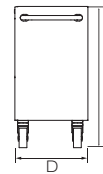
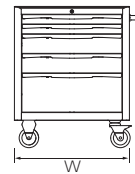

ROLLER CABINET (7 STAGES, 7 DRAWERS)



EKW-1007R



EKW-1007BK



EKW-1007



EKW-1007WH

No.	Weight(kg)	⊠	
EKW-1007R(Red)	82	1	
EKW-1007BK(Black)	82	1	
EKW-1007(Silver)	82	1	
EKW-1007WH(White)	82	1	

Body size	W740×D470×H910(Including caster H180) Handle protrusion 85 φ29 Top section Load capacity140kg Maximum load capacity 350kg (including product weight)
Top Size	w720×d460
Drawer size	w600×d405×h 45×4 Load capacity15kg w600×d405×h105×3 Load capacity20kg
Top mat×1 Drawer mats×7 Dividers×4 Keys×2	

· When all drawers are closed and locked, all drawers can be locked at the same time. All drawers locking system is adopted.

\* Repair parts are set.

For details, please contact the distributor.

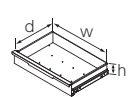
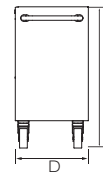

Widebody



Wide body that can accommodate long items horizontally. Highly practical size setting that prioritizes usability at maintenance sites.

Two-way locks & large wheels



The swivel casters have a two-way lock mechanism that locks the rotation of the wheels and the rotation of the pedestal at the same time.

Inner frame CO<sub>2</sub> and spot welding

The flat sides which are a feature of the EKW, are realized by the rigidity of the inner frame. The EKR also uses a similar inner frame structure.



Round shape

The parts that people touch are thoroughly bent. We have treated not only the outside but also the cross section of the drawer to reduce the risk of cuts and other injuries.



· Do not pull out more than two drawers at the same time. Possible to be fall down.  
Do not disassemble or modify the product.

# ROLLER CABINET (8 STAGES, 8 DRAWERS)

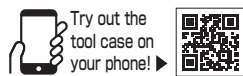

No.	Weight(kg)	☐	
EKX-118	110	1	
Body size	W740×D540×H1,230		
Drawer size (1st to 3rd drawer)	w600×d325×h55	Load capacity15kg	
Drawer size (4th drawer)	w600×d410-435×h100	Load capacity20kg	
Drawer size (5th to 6th drawer)	w600×d410×h40	Load capacity15kg	
Drawer size (7th drawer)	w600×d410-435×h100	Load capacity20kg	
Drawer size (8th drawer)	w600×d410-435×h290	Load capacity30kg	
* The depth of the 4th and 7th-8th tiers differs in size between the opening and the bottom. (See the figure below)			
Dividers×6 Drawer mats×8 Keys×2			

\* Repair parts are set.  
For details, please contact the distributor.

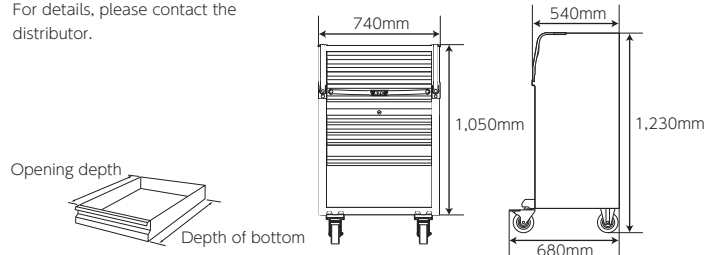

## Safety and comfort features throughout

### Wide & Low Body

Compact but with increased storage capacity and an ingenious trapezoidal shape that is easy to use  
By integrating a cabinet and a chest into one unit, extra structures are eliminated and volume efficiency is greatly improved. The overall height is determined from the average height of Japanese people, making it easy to access even the top drawer.  
The upper part of the body has an original trapezoidal shape. The drawers open in a tiered stand pattern, allowing the stored items to be seen at a glance.  
To prevent the cabinet from tipping over, the center of gravity of the 1st to 3rd drawers is placed at the rear, and the 4th to 8th drawers have a safety lock mechanism that only opens one drawer at a time.  
All drawers can be locked at the same time when all drawers are closed and locked.

Drawer Side View

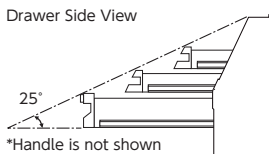

\*Handle is not shown

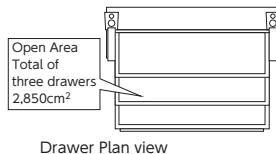

Drawer Plan view

### Soft-closing drawer

Soft suction rails are used to pull drawers in slowly (4 to 8 drawers only). A soft-closing mechanism is adopted, in which a brake is applied just before the drawer closes, and the drawer is then slowly retracted. This provides a high quality operating feel.

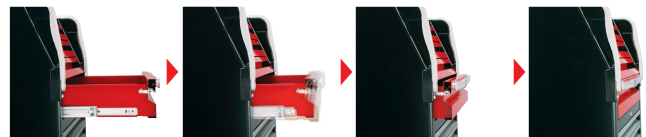

### Two-way lock and long wheelbase casters

**Safety design to prevent cabinet tipping over**  
The front swivel casters have a two-way lock mechanism that locks the rotation of the wheels and the rotation of the pedestal at the same time. The long wheelbase design offset to the outside of the main body improves stability and prevents the cabinet from tipping over.

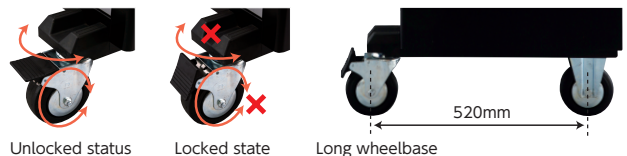

- Function mark is indicated under the product name. For the details, please refer to P.004-005.
- Products marked with ⚠ should be ordered after checking stock.
- Do not pull out more than two drawers at the same time. Possible to be fall down.



Spare parts Repairable



ROLLER CABINET (5 STAGES, 5 DRAWERS)



SKX3805



SKX3805BK



SKX3805S

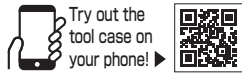

No.	Weight(kg)	☐
SKX3805(Red)	60	1
SKX3805BK(Black)	60	1
SKX3805S(Silver)	60	1

Body size	W680×D460×H975
Handle	Protrusion 100 φ26
Top part	w675×d455 Load capacity140kg
Drawer size	w580×d405×h 60×2 Load capacity15kg
	w580×d405×h135×2 Load capacity20kg
	w580×d405×h210×1 Load capacity30kg

- Top mat×1 Drawer mats×5 Dividers×5 Keys×2
- The swivel casters have a two-way lock mechanism that locks the rotation of the wheels and the rotation of the pedestal at the same time.
- Ball bearing slide rails are used for smooth opening and closing of drawers.
- All drawers can be locked at the same time when all drawers are closed and locked.

\* Repair parts are available. Please contact our distributors for details.

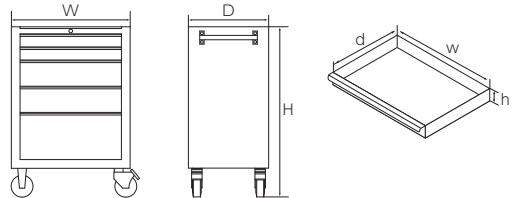

ROLLER CABINET (7 STAGES, 14 DRAWERS)

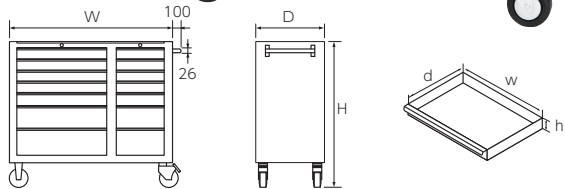

No.	Weight(kg)	☐
SKX3814	106	1

Body size	W1,045×D460×H975
Handle	Protrusion 100 φ26
Top part	Load capacity180kg
Drawer size	w580×d405×h 60×5 Load capacity15kg
	w580×d405×h135×2 Load capacity20kg
	w300×d405×h 60×5 Load capacity10kg
	w300×d405×h135×2 Load capacity15kg

Top mat×1 Drawer mats : large×7, small×7 Dividers×5 Keys×4 (2×2)

- The swivel casters have a two-way lock mechanism that locks the rotation of the wheels and the rotation of the pedestal at the same time.
- Ball bearing slide rails are used for smooth opening and closing of drawers.
- All drawers can be locked at the same time when all drawers are closed and locked.
- Drawers can be locked by rows on either side.
- \* The key numbers on the left and right sides are the same.
- \* Repair parts are available. Please contact our distributors for details.

ROLLER CABINET (7 STAGES, 12 DRAWERS)

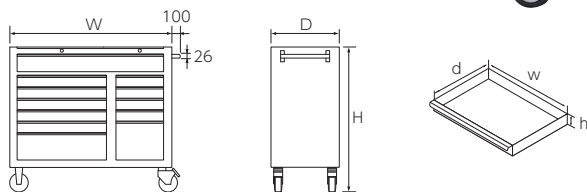

No.	Weight(kg)	☐
SKX3812	103	1

Body size	W1,045×D460×H975
Handle	Protrusion 100 φ26
Top part	Load capacity180kg
Drawer size	w945×d405×h 95×1 Load capacity15kg
	w580×d405×h 75×5 Load capacity15kg
	w580×d405×h150×1 Load capacity20kg
	w300×d405×h 75×4 Load capacity10kg
	w300×d405×h225×1 Load capacity15kg

Top mat×1 Drawer mat for 1st drawer×1, Large×6, Small×5 Dividers×5 Keys×4 (2×2)

- The swivel casters have a two-way lock mechanism that locks the rotation of the wheels and the rotation of the pedestal at the same time.
- Ball bearing slide rails are used for smooth opening and closing of drawers.
- All drawers can be locked at the same time when all drawers are closed and locked.
- The drawers can be locked per row on the left and right. (The first row is included in the left drawer.)
- \* The key numbers on the left and right sides are the same.
- \* Repair parts are set. For details, please contact the distributor.

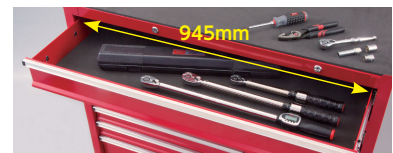

The top drawer can hold torque wrenches, breaker bars, and other long items. (Tools are sold separately)

• Do not pull out more than two drawers at the same time. Possible to be fall down.  
Do not disassemble or modify the product.

MECHANIC DESK CASE



No.	Weight(kg)	□	
SK200-M	50	1	
Body size	W575×D485×H880		
Drawer size	w500×d405×h50 w500×d405×h85		
Dividers: large×4, medium×6, small×5	Top mat ×1		
Tool holder ×1	Binder stand×1		
Spray can stopper ×2	Basket ×1		
Pipe with magnet base ×1	Keys ×2		

• This case was developed for automobile maintenance. Practical functions increase work efficiency.  
\* Repair parts are available. Please contact our distributors for details.

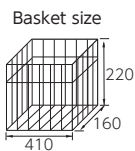
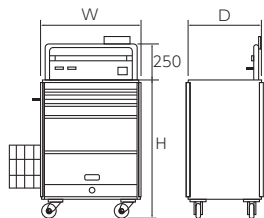

- Includes a strong magnetic base for temporary storage of tools.
- Includes a spray can holder that can be fixed with a single touch.
- Includes a binder stand for work inspection charts, etc.
- Includes a card holder that identifies the owner.



- It is equipped with a divider to manage tools.
- The side has a drawer for storing small items.
- The front drawer cannot be pulled out at the same time to prevent it from tipping over.

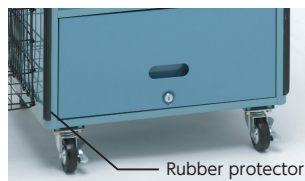

- This is a lockable storage container for storing instruments, parts, and other items.
- Equipped with rubber protectors to prevent scratching other machines.
- All wheels are flexible, and two of them have stoppers.

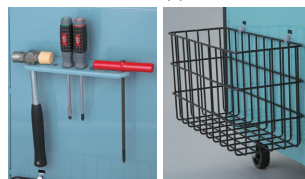

- Includes a convenient holder for storing hammers and other items.
- Includes a basket for waste, rags, etc.

\* Tools and spray cans in the photo are sold separately.

WORK TRUCK CASE



No.	Weight(kg)	□	
SK300-M	50	1	
Body size	W700×D450×H890		
4 dividers for boxes, 1 divider for sockets, 2 dividers for middle dishes	T-shape wrench hanger ×1		
Grease pump holder ×1	Basket ×1		
Keys ×2			

• The case was developed for heavy-duty vehicle maintenance and is easy to store and functional.  
\* Repair parts are available. Please contact our distributors for details.

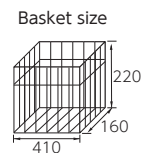
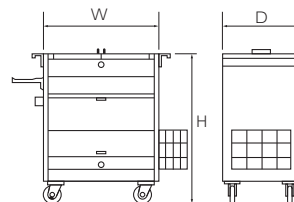

- The top lid is made of 2mm-thick steel plate so that it can be used as a workbench.
- The upper box has dividers for easy organization of large size tools.



- A convenient holder for storing hammers, grease pumps, etc.



- Includes a basket for waste, rags, etc.

TOOL STATION

TOOL STORAGE

ROLLER CABINET AND WAGON



Try out the tool case on your phone!



\* The photo is for illustrative purposes only. Do not open more than one drawer at a time.

No.	Weight(kg)	☐	
SKR703A	39	1	

Body size	W670×D420×H900
Tray size	w478×d360×h45×3 Movable type(Load capacity10kg)
Top mat×1	
Dividers×8	
Dial lock×1	

- This is a high-grade model.
- The shutters can be locked, making them ideal for managing stored items.
- The load capacity of the top panel is up to 140 kg.
- \* Repair parts are available. Please contact our distributors for details.

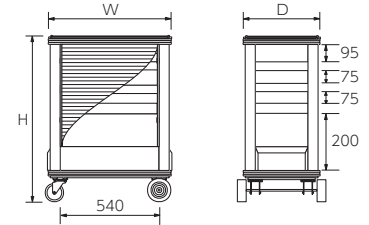

Try out the tool case on your phone!



\* The photo is for illustrative purposes only. Do not open more than one drawer at a time.

No.	Weight(kg)	☐	
SKR602A	30	1	

Body size	W670×D420×H900
Tray size	w510×d360×h45×2 Movable type(Load capacity10kg)
Top mat×1	
Dividers×8	

- Standard model.
- The front and back sides are easily identifiable, and the space inside the cabinet can be used effectively, making it more practical and functional.
- The load capacity of the top panel is up to 140 kg.
- \* Repair parts are available. Please contact our distributors for details.

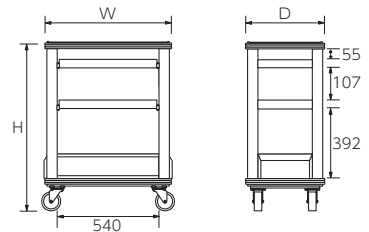

Try out the tool case on your phone!

No.	Weight(kg)	☐	
SKR502A	26	1	

Body size	W670×D420×H900
Tray size	w535×d360×h45×2 Fixed type(Load capacity15kg)
Top mat×1	
Dividers×8	

- Basic model.
- The front and back sides are easily identifiable, and the minimum necessary functions are integrated.
- The load capacity of the top panel is up to 140 kg.
- \* Repair parts are available. Please contact our distributors for details.

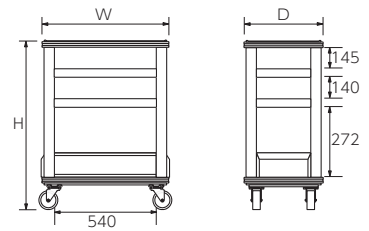

Try out the tool case on your phone!



\* The photo is for illustrative purposes only. Do not open more than one drawer at a time.

No.	Weight(kg)	☐	
SKR402A	27	1	

Body size	W670×D420×H770
Tray size	w510×d360×h45×2 Movable type(Load capacity10kg)
Top mat×1	
Dividers×8	

- Compact model.
- The height is 770mm, which is lower than other models.
- The overall height has been lowered to allow work to be performed at a lower position.
- The entire pit can be kept spacious because it can be stored in places where it could not fit in the past.
- The load capacity of the top panel is up to 140 kg.
- \* Repair parts are available. Please contact our distributors for details.

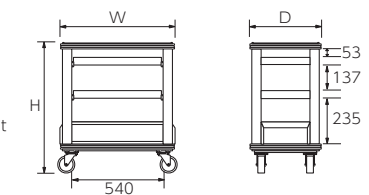

• Do not pull out more than two drawers at the same time. Possible to be fall down.  
Do not disassemble or modify the product.

ACCESSORIES FOR TOOL STATION



SCREWDRIVER STAND

No.	
SKR-51	
* Cannot be used with punching board.	

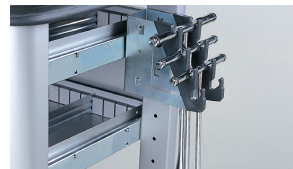

T-SHAPED WRENCH HOLDER

No.	
SKR-52G	
Set of 2.	
* Cannot be used with punching board.	



SPRAY CAN HOLDER

No.	
SKR-53	
* Cannot be used with punching board.	

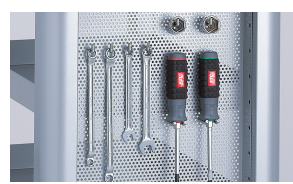

SIDE PUNCHING BOARD

No.	
SKR-54S	
Panel hole diameter 3mm dia.	
Applicable to SKR502A and SKR602A	
Accessories / 4 each of hooks A, B, and C	

\* The tools and spray cans in the photo are examples of storage and are not included in the listed price.

Optional parts Hook set for side punching board

Description	No.	Number	Shape	Application examples
Hook A set	SKR-54-A	10		Socket (small size), etc.
Hook B set	SKR-54-B	10		Ratchet handle, Box end wrench (small size), etc.
Hook C set	SKR-54-C	10		Open end wrench, combination Wrench (small size), etc.
Hook D set	SKR-54-D	10		Box end wrench (large size) Hammers, pliers, screwdrivers, etc.

Description	No.	Number	Shape	Application examples
Hook E set	SKR-54-E	10		Socket (Large size) etc.
Hook J set	SKR-54-J	10		Pliers handles, driers, etc. Drivers, etc.
Hook K set	SKR-54-K	10		Deep sockets, etc.

Hook screw (M3 x pitch 0.5, shaft dia. 5 mm)

WAGON (1 STAGE, 2 DRAWERS)



Customer-assembled products

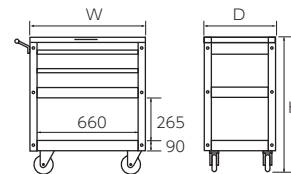
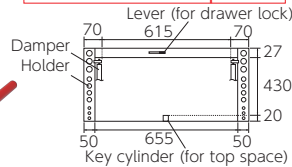

No.		Weight(kg)	☐	
SKX2614		48	1	

Body size	W775×D515×H880
Drawer size	w630×d445×h65×2 Load capacity25kg
Bottom shelf size	w755×d480×h90×1 Load capacity50kg
Top mat×1 Drawer mats×2 Tray mat×1	

- Free casters (φ 100×30 mm) are used on all wheels. (Two of the wheels have stoppers.)
- The top opens to allow the tool to enter. Both sides have holders for screwdrivers, etc.
- Two-step locking system  
Drawer locks can be operated with a lever inside the top, the top section can be locked with a key.
- \* Repair parts are available. Please contact our distributors for details.



(State when the top is open)  
\* Tools are sold separately.

WAGON (4 STAGES, 1 DRAWER)



Customer-assembled products

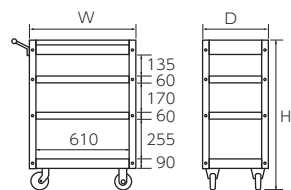
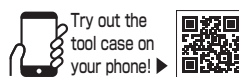

No.		Weight(kg)	☐	
SKX2704		29	1	

Body size	W715×D410×H1,011
Drawer size	w570×d275×h65×1 Load capacity5kg
Intermediate shelf size	w705×d400×h60×2 Load capacity15kg
Bottom shelf size	w705×d400×h90×1 Load capacity20kg
Top mat×1 Drawer mat×1 Tray mats×3	

- Free casters (two wheels) with stopper, fixed casters (two wheels). (φ 100×30mm)
- Chests, etc. can be added on top. SKX0213,SKX0213S,SKX0213BK can be placed on the top section.(Top section load capacity 20kg)
- The two intermediate shelves can be lowered by approximately 100 mm.
- \* Repair parts are available. Please contact our distributors for details.

WAGON (3 STAGES, 1 DRAWER)



SKX2613

SKX2613BK2

Customer-assembled products

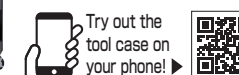

SKX2613S2

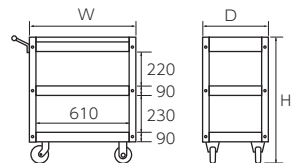

No.		Weight(kg)	☐	
SKX2613(Red)		24	1	
SKX2613BK2(Black)		24	1	
SKX2613S2(Silver)		24	1	

Body size	W715×D410×H880
Drawer size	w570×d275×h65×1 Load capacity5kg
Intermediate shelf size	w705×d400×h90 (Intermediate shelf load capacity 15kg)
Bottom shelf size	w705×d400×h90 (Bottom shelf load capacity 20kg)
Top mat×1 Drawer mat×1 Tray mats×2	

- Free casters (two wheels) with stopper, fixed casters (two wheels). (φ 100×30mm)
- Chests, etc. can be added on top. SKX0213,SKX0213S,SKX0213BK can be placed on the top panel.(Top section load capacity 20kg)
- \* Repair parts are available. Please contact our distributors for details.

- Function mark is indicated under the product name. For the details, please refer to P.004-005.
- Products marked with should be ordered after checking stock.
- Do not pull out more than two drawers at the same time. Possible to be fall down.



Spare parts Repairable

## TOOL STORAGE

---

## TOOL BOXES

Watch video!  
How to use the case



Carrying out



Open and close

SPLIT OPEN METAL CASE

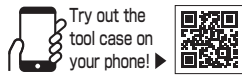

EK-10AR3



EK-10AGBK



EK-10A



EK-10AWH



Carrying tray

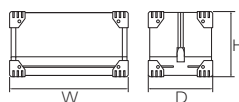

No.	Weight(kg)	☐	
EK-10AR3(Red)	7.1	1	
EK-10AGBK(Black)	7.1	1	
EK-10A(Silver)	7.1	1	
🔧 EK-10AWH(White)	7.1	1	

Body size	W440×D233×H230
Carrying tray size	w385×d100×h45

- The product can be locked with padlocks, etc. (This product is not equipped with a key.)
- A removable carrying tray is set in the upper section. Only the necessary items can be placed in the tray for easy transportation to the work site.
- The built-in handle stores flat and can be carried quickly without the need to raise or fold the handle.
- Corner pads protect the body even under hard use.
- The corner pads are made of resin with excellent impact and scratch resistance.
- Material is steel.
- \* Carrying tray is available as a repair part. Please contact your dealer for details.

Feature



**Easy-to-grab handle shape**  
The handles can be carried with a single action of "grab the handles and lift".



**Folding mechanism**  
The aluminum die-cast handle retracts flat with a simple release of the hand.



**Corner pad with a strong presence**  
Resin pads are used to prevent damage to flooring and other surfaces.



**Locking prevents theft of tools**  
Can be locked with a padlock (sold separately).



**YG-258R**  
Combination Padlock



**YG-259**  
Padlock

SPLIT OPEN PLASTIC HARD CASE

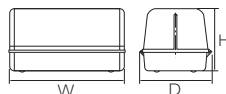

No.	Weight(kg)	☐	
SK330P-M	4	1	

Body size	W445×D280×H250
Key×1 Dividers×6	

- Approximately 40% lighter than the double-door metal case EK-10A.
- This is an excellent oil-resistant and impact-resistant product.
- The grips and locks are flat, eliminating any obtrusive protrusions.
- \* Repair parts are available. Please contact our distributors for details.



Open time



Flattened grips and locks

SPLIT OPEN METAL CAS (MOVABLE HANDLE)

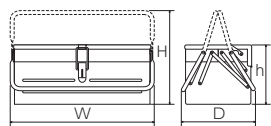

No.	Weight(kg)	☐	
SKC-MA	3.9	1	

Body size	W460×D230×H280(Including handle) When handle is down: h190
Internal dimensions of main unit	w410×d198×h130
Tray size	w410×d87×h49×2 Tray divider mounting pitch: 57 Tray dividers×12

• Function mark is indicated under the product name. For the details, please refer to P.004-005.  
• Products marked with 🔧 should be ordered after checking stock.



**METAL CASE**

TOOL STORAGE

No.	Weight(kg)	☐	
EK-3	2.3	1	
Body size	W410×D210×H150		
Carrying tray size	w385×d100×h45		

- The door can be locked with a padlock or other means. (Lock hole diameter: φ5; this product does not come with a key.)
- The handle does not protrude when stored.
- Includes a fixed tray for storing screws and other parts and small items.
- The carrying tray (made of metal) with a handle is an excellent item that can be removed from the main case and carried.
- Material is steel.
- \* Carrying tray is set as a repair part. For details, please contact the dealer. Please contact us.

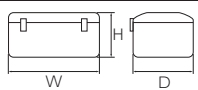

No.	Weight(kg)	☐	
EK-5	1	1	
Body size	W375×D165×H110		

- The small metal case follows the design of the stylish EK series.
- The product can be locked with padlocks, etc. (This product is not equipped with a key.)
- It is convenient for sorting tools in the factory or carrying only the tools you use to your work area.
- When stored, the handle does not protrude and the top is flat, making it easy to place items on top of the case.
- Material is steel.

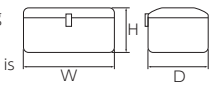

No.	Weight(g)	☐	
EKB-1	800	1	
Body size	W275×D150×H50		

- Convenient for management of tools and parts.
- Material is steel.

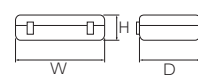

No.	Weight(kg)	☐	
EKB-2	1.6	1	
Body size	W455×D190×H60		

- Trunk type metal case (with handle).
- Convenient for management of tools and parts.
- Material is steel.

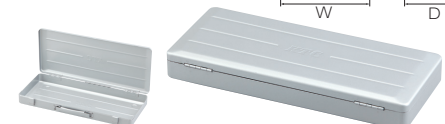
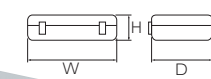

TOOL BOXES

No.	Weight(g)	☐	
EKB-3	600	1	
Body size	W275×D150×H35		

- Convenient for management of tools and parts.
- Material is steel.

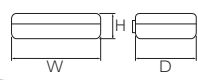

No.	Weight(kg)	☐	
SK120-M	4	1	
Body size	W405×D200×H170		
Medium dish size	w385×d100×h45		
Carrying tray size	w385×d100×h40		
Parts dish size	w155×d65 ×h20		

- The size is convenient for storage and carrying.
- \* Carrying tray is set as a repair part. For details, please contact the distributor.

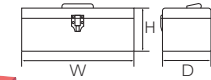

No.	Weight(kg)	☐	
B4110-MA	3.1	1	
Body size	W545×D185×H85		
Inside dimensions	w530×d170×h80		

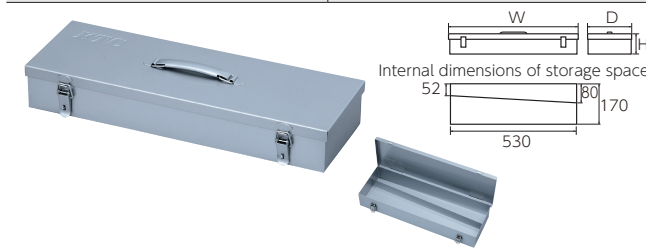

No.	Weight(kg)	☐	
TBP614TP-M	2.9	1	
Body size	W545×D160×H85		
Inside dimensions	w530×d130×h80		

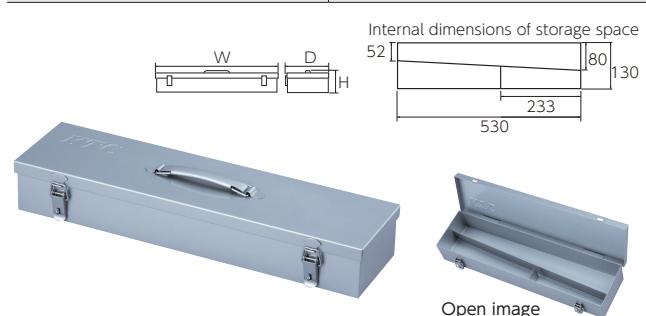

No.	Weight(kg)	☐	
ABP-M	1.2	1	
Body size	W310×D165×H70		
Inside dimensions	w300×d140×h60		

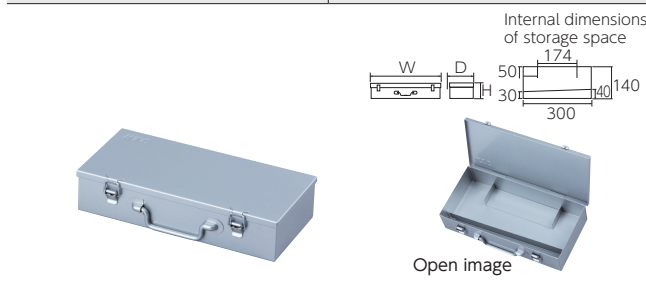

• Do not use the product for any purpose other than its original use.

## PLASTIC HARD CASE

No.	Weight(kg)	☐	
EKP-1A	3.4	1	
Body size	W540×D360×H350		
Medium dish size	w210×d320×h90		
Internal dimensions (when using a medium-sized plate)	w410×d275×h200		



No.	Weight(kg)	☐	
EKP-2	2.5	1	
Body size	W530×D253×H220		
Medium dish size	w510×d200×h58		
Internal dimensions (when using a medium-sized plate)	w480×d188×h110 Dividers for medium-sized plates: large×4, small×2		

- We use a resin material with excellent impact resistance and durability, and ensure high strength through appropriate rib placement.
- The storage space for the middle dish can be adjusted by using the divider for the middle dish.



No.	Weight(kg)	☐	
EKP-3	1.2	1	
Body size	W443×D216×H160		
Medium dish size	w404×d156×h33		
Internal dimensions (when using a medium-sized plate)	w405×d162×h80 Cutting board for medium dish×8		



No.	Weight(g)	☐	
EKP-5	900	1	
Body size	W385×D202×H140		
Medium dish size	w345×d148×h32		
Internal dimensions (when using a medium-sized plate)	w345×d150×h65 Cutting board for medium dish×2		



## INNER TRAY FOR PLASTIC HARD CASE

No.	Weight(g)	☐	
EKP-1A-1	400	1	
Body size	W210×D320×H90		
Inside dimensions	w190×d280×h80		

\* This is a medium plate exclusively for EKP-1A.



## PLASTIC HARD CASE

No.	Weight(g)	☐	
TCP1-1	800	1	
Body size	W385×D190×H65		
Inside dimensions	w380×d185×h60		

• The tool case is made of lightweight and durable plastic.

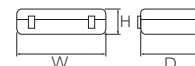

## ACTIVE BUDDY

No.	Description	Weight(g)	☐	
EK-50PH	Active Buddy Slim	670	1	
Body size	W340×D290×H75			
Inside dimensions	w320×d215×h60 (30+30)			

• ATB34P16 and ATB3P10 (P.573) with special inlays.



EK-50PH

No.	Description	Weight(g)	☐	
EK-30PH	Active Buddy Pocket	100	1	
Body size	W120×D120×H40			
Inside dimensions	w110×d90×h30			

• ATB3P10 (P.573) with special inlay.



EK-30PH

No.	Description	Weight(g)	☐	
EK-25PH	Active Buddy Mini	50	1	
Body size	W105×D85×H40			
Inside dimensions	w90×d60×h30			

• ATPBRZ8603 (P.574) with special inlay.



EK-25PH



WALL HUNG TOOL CHEST (AUTOMOTIVE)



No.	Weight(kg)	⊞	
MK91A-M	18	1	
Body size	W1,125×D145×H630		
Color	Shutter: Silver, Tool hanging panel: Black		

- Tools can be hung according to shadow pictures.
- Sliding shutter to prevent theft.
- The door can be locked with a padlock or other means.  
(This product does not have a key.)

**CAUTION** • Installation by anchors is required.

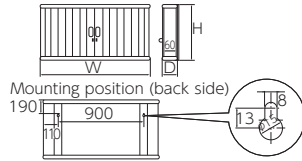

WALL HUNG TOOL CHEST (INDUSTRIAL)

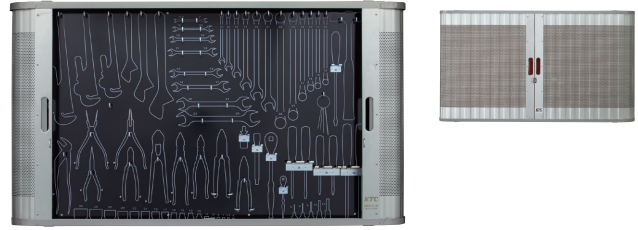

No.	Weight(kg)	⊞	
MK81A-M	18	1	
Body size	W1,125×D145×H630		
Color	Shutter: Silver, Tool hanging panel: Black		

- Tools can be hung according to shadow pictures.
- Sliding shutter to prevent theft.
- The door can be locked with a padlock or other means.  
(This product does not have a key.)

**CAUTION** • Installation by anchors is required.

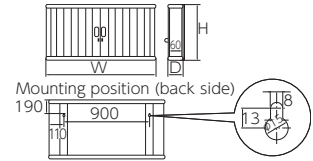

THIN METAL STORAGE CASE

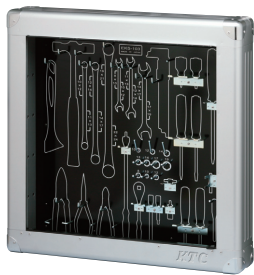

Tool storage example  
\* Tools are sold separately.

No.	Weight(kg)	⊞	
EKS-103	14	1	
Body size	W600×D145×H600		

- Thin storage metal case for tool set SK3560SS. It is shadow-painted and convenient for tool management. (For details on SK3560SS ▶ P.158)

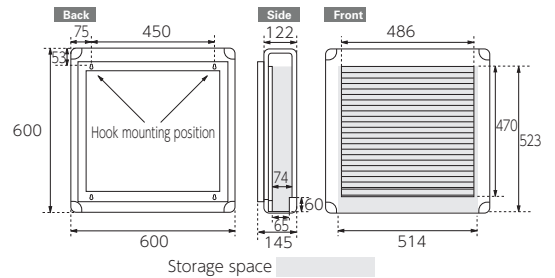

**CAUTION** Anchor installation is required regardless of whether it is wall-mounted or stand-mounted. The wall should be reinforced depending on the wall material and structure.

DESK TOP STAND FOR METAL CASE

Dedicated to EKS main unit



Easy assembly with 4 bolts on the back.

No.	L	W	H	h	T	Weight(kg)	⊞	
EKS-301	240	50	197	55	3.2	2.6	1	

- This desktop stand follows the concept of the next-generation storage device "EK series" and allows the thin storage metal case "EKS-103" to be used independently. It is fixed to the back of the case with four bolts.
- This is a dedicated desktop stand for the "EKS-103" thin storage metal case.
- The depth of the installation surface is as thin as 240 mm, providing work space even when placed on a desk.
- By tilting the case 10 degrees, it improves stability and makes it easier to check stored tools.

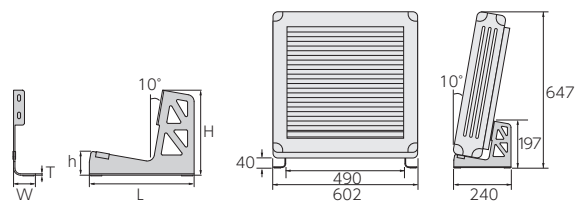

• Do not use the product for any purpose other than its original use.

**TOOL STORAGE**

---

**STORAGE  
ACCESSORIES**

TOOL BAG (BLACK)



No.	Expanded size	Weight(g)
MCKB-B	260×490 (excluding belt and flap)	270

- This is a tool bag used in the Riders Maintenance Tool Set (MCK3140 P.171, P.608).
- Material: Nylon (main body), PVC (back of main body), PP (edge, tape)

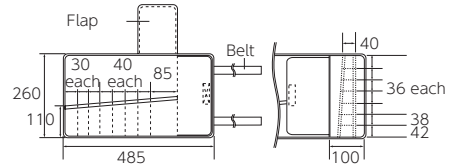

\* Folding dimensions will vary depending on the contents of the assembly.

MINI CHEST & MINI CABINET SET



- \* Tools are sold separately.
- \* The photo is for illustrative purposes only. Do not open more than one drawer at a time.

No.	Weight(kg)	□
SKX0010R	7.5	1

Set contents	
SKX0012	Mini chest (2 tiers 2 drawers)
SKX0514	Mini cabinet (4 tiers, 4 shelves)

- Comfortable storage for tools, accessories and parts. A hobby case crams authentic features.
- \* Repair parts are available. Please contact our distributors for details.

MINI CHEST (2 STAGES, 2 DRAWERS)

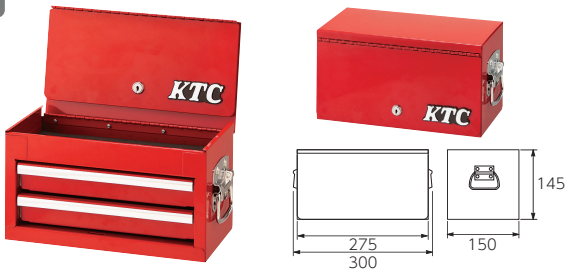

No.	Weight(kg)	□
SKX0012	3.1	1

Body size	W300×D150×H145(Including side handle)
Top Size	w270×d140×h30×1
Drawer size	w215×d130×h38×2
Top mat×1 Drawer mat×2	

\* Repair parts are available. Please contact our distributors for details.

MINI CABINET (4 STAGES, 4 DRAWERS)



No.	Weight(kg)	□
SKX0514	4.4	1

Body size	W320×D150×H285(Including side handle)
Drawer size	w215×d130×h38×3 w215×d130×h80×1
285 Drawer mats×4 Mini-cabinet exclusive mats×1 (cannot be locked)	

\* Repair parts are available. Please contact our distributors for details.

MAGNETIC T-SHAPED WRENCH HOLDER



No.	W	D	H	Weight(g)	□
YKHD-5TM	110	155	180	370	1

- Holders for T-shape wrenches that can be attached with magnets.
- The arm can be folded down when not in use.
- Rubber mat prevents slipping and falling.



- Do not carry more than the load capacity.
- Install on a flat steel plate at least 0.8 mm thick.

Load capacity : 3kg

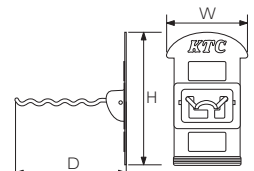

- Do not use the product for any purpose other than its original use.
- Do not pull out more than two drawers at the same time. Possible to be fall down.

### MAGNETIC PAPER HOLDER



Condition of use

No.	W	D	H	Weight(g)	☐
YKHD-RPM	130	85	102	640(2 pcs)	1

- Rolls of paper towels can be attached with magnets.
- The left and right independent type supports paper waste up to  $\phi$  120mm and width 500mm.
- Strong rubber magnets prevent the product from slipping off.



- Do not carry more than the load capacity.
- Install on a flat steel plate at least 0.8 mm thick.

Load capacity : 1kg

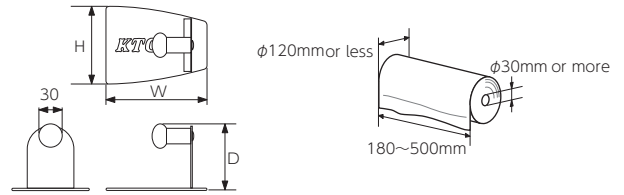

### MAGNETIC SPRAY CAN HOLDER



Condition of use

No.	W	D	H	Weight(kg)	☐
YKHD-02	405	100	134	1.1	1

- Accessories: 2 mounting screws, 2 mounting spacers, 1 non-slip sheet.
- Applicable: Spray cans with a diameter of 76 mm or less and a height of 350 mm or less.

- Features:
  - 4-hole type that can be attached to cabinets, etc. with strong magnets.
  - The deep holder can hold long cans of parts cleaner, etc.
  - The non-slip sheet prevents storage items from tipping over and also reduces noise during storage.
  - Both side covers are made of resin.
  - The magnets on the back are equipped with rubber to prevent damage to the object to which they are attached.
  - Can be screwed with the supplied mounting screws and spacers. (Applies to our EKW-1000 series and SKX3000 series roller cabinets)

Load capacity : 4kg



- Do not carry more than the load capacity.

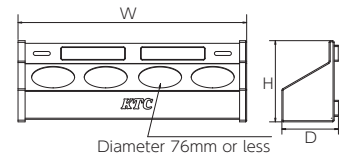

### MAGNETIC SPLAY CAN HOLDER



Example of use (left: parts cleaner, right: filter oil catcher)

No.	Weight(g)	☐
YKHD-04	400	1

- Purpose: Holders for storing spray cans by attaching them to the sides of cabinets, etc.
- Adoption: Diameter 62-74mm, weight 3kg or less
- Compatible with filter oil catcher (AVP-6376 P.510)
- Features: Rubber is attached to the back magnet to prevent damage to the object to which it is attached.



- Do not carry more than the load capacity.

Load capacity : 3kg

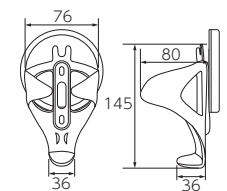

### MAGNETIC PARTS BOWL

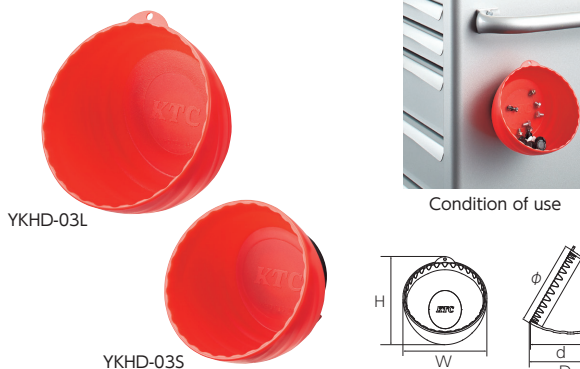

Condition of use

YKHD-03L

YKHD-03S

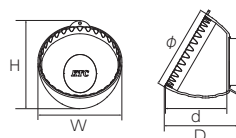

No.	Body Material	$\phi$ (Outer diameter)	W	D	d	H	Weight(g)	☐
YKHD-03S	ABS	114	114	99	83	113	180	1
YKHD-03L	ABS	153	153	132	114	161	380	1

- Purpose: Storage bowl for screws, parts, small parts, etc.
- Features:
  - Can be freely attached to cabinets, etc. with strong magnets.
  - Screws removed during work are stored to prevent loss, etc.
  - The deep bowl shape enables storage of plastic parts and other items that do not attach to magnets.
  - ABS is used, which is resistant to breakage and has excellent oil resistance.
  - The plastic construction prevents accidental injury and damage to parts.
  - The magnet part is equipped with rubber to prevent damage to the object to which it is attached.



- The resin is not heated.
- Do not carry more than the load capacity.

Load capacity : 1kg

Common to YKHD-03S and 03L

· Function mark is indicated under the product name. For the details, please refer to P.004-005.  
 · Products marked with should be ordered after checking stock.



MAGNETIC DRIVE HOLDER

- 1/4" sq.
- 3/8" sq.
- 1/2" sq.



No.	sq.	L	Weight(g)	☐	☐
YKHD-A2	1/4"	27	140	1	
YKHD-A3	3/8"	31	140	1	
YKHD-A4	1/2"	36	145	1	

- Can be attached to cabinets, etc. with strong magnets.
- Handles that tend to roll around in drawers can be stored stably.
- The ball groove at the drive size securely holds handles.
- \* Ratchet handle is not included in the product.

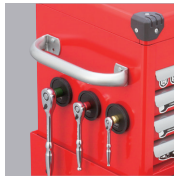

Condition of use  
\* Tools are sold separately.

Load capacity : 900g

\* Only when stationary

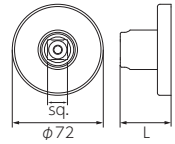

MAGNET SHEET

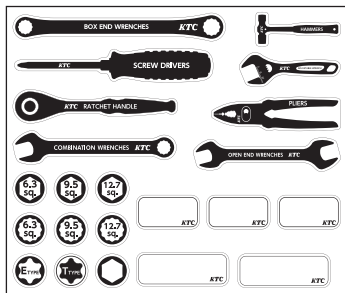

No.	Sheet size	Weight(g)	☐	☐
EHMG-1	W290×H245	280	1	

- The "Storage" function allows you to check the storage location at a glance by attaching it to cabinets, etc.
- It can also be used as a memo pad.
- The height of the magnet is standardized at 29mm.
- \* Please make sure that the height of the affixed area is at least 29mm.



Condition of use

MAGNETIC IMPACT WRENCH HOLDER

- 1/2" sq.
- Repair Spare parts



YKHD-01

No.	W1	W2	D	H	Weight(kg)	☐	☐
YKHD-01	150	104	110	380	1	1	

- Adoption
- 1/2"sq. impact wrench with hammer case of 82mm or less.
  - 1/2"sq. socket.
- Features
- Can be attached to cabinets, etc. with strong magnets.
  - Impact wrenches are neatly stored and can be smoothly removed.
  - The impact wrench holder is non-slip to prevent accidental dropping.
  - Includes a holder to hold a 1/2"sq. socket.
  - (Cannot be inserted into the socket holder with the pin/ring attached)
  - The magnets on the back are equipped with rubber to prevent damage to the object to which they are attached.



Condition of use  
\* Tools are sold separately.

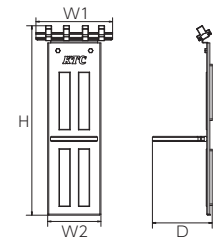

Load capacity : 5kg

- WARNING** • Always disconnect the air hose when storing the impact wrench.

- CAUTION** • Do not carry more than the load capacity.

Spare parts

No.	Description	Weight(g)	☐	☐
YKHD-01A	Clip set for impact wrench holder [4pcs.]	10		

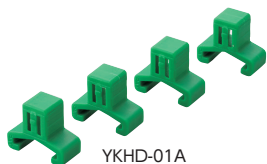

YKHD-01A

• Do not use the product for any purpose other than its original use.

WRENCH RACK

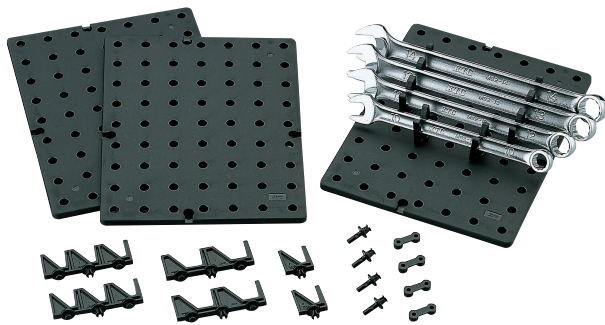

Condition of use \* Tools are sold separately.

No.	
TEH1SM	
Set contents	
Base	180×140×5.5×3
Rack pin A	For small size (up to about 19×21) 3 Hangings×4
Rack pin B	For large size (about 19×21 to 24×27) 2 hangers×2
Rack pin C	For small size 1 hanging×4
Pin	×4
Joint	×4

- The tool box can be used to neatly store tools in a tool box or cabinet.
- \* Three pieces can be placed side by side to fit into EKR-103A( P.187) or SKX0213, SKX0213S, SKX0213BK( P.188).
- The bases can be freely reconfigured and the rack pins can be arranged to suit your own preferences.
- The material used is PP resin. It is lightweight and has excellent chemical resistance.

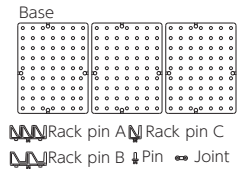

Spare parts

No.	Description	Qty
EH1SM210	Rack pin A	10
EH1SM310	Rack pin B	10
EH1SM410	Rack pin C	10
EH1SM510	Pin	10
EH1SM610	Joint	10

GARAGE MAT



No.	Size	Weight(kg)	□
EKR-701	W900×D600	1.3	1

- This is a general-purpose mat that can be used in a variety of maintenance scenarios.
- Prevents scratches on the floor and cases by placing it under chests and double-drawer cases. It also prevents scratches and stains caused by placing parts directly on the floor.
- When working in a low position, such as kneeling, the mat can reduce knee pain.
- Material: Polypropylene

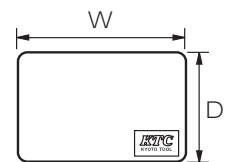

We have a lineup of trays for various types of storage equipment. For details, please visit the website.



\* Tools are not included in the product.

• Function mark is indicated under the product name. For the details, please refer to P.004-005.  
 • Products marked with should be ordered after checking stock.

